

SMALL EM OIL SEALED ROTARY VANE PUMPS

 **EDWARDS**





PERFORMANCE YOU CAN RELY ON

Edwards EM pumps are designed for reliable, long term operation

Our EM range of small oil sealed rotary vane pumps are renowned for achieving high ultimate vacuum and rapid pumping speeds, with quiet operation and exceptional reliability. These pumps have become the industry standard in a range of scientific and laboratory applications, and are ideal for backing small turbomolecular pumps.

- Single and two stage design options
- Pumping speeds from 0.7 to 28 m³h⁻¹
- Simple installation and operation with no customer wiring
- Range of accessories available
- Internal ATEX classification of II 3 G Ex h IIB T4 Gc
- Approved to EN61010, CSA22.2 and UL61010
- Fully RoHS compliant

Quiet operation

For a better working environment

Flexibility of use

Free standing unit and compact design

Reliable performance

Proven in a range of laboratory and industrial applications over many years

Gas ballast valve

Used when pumping vapour



EM ROTARY VANE PUMP TECHNOLOGY





1. Easy control

IEC connector and on/off switch for local control



4. Forced air cooling

Optimal operating conditions for the pump whilst controlling the temperature of accessible surfaces



2. Works where you are

You can select the appropriate motor for your country



5. Easy oil top ups

Thanks to a large oil filling port and recessed top in the oil box



3. Large water vapour handling capacity

Gas ballast valve can be used to help pumping vapour and conditioning the oil so you get the optimal performance out of your pump.



6. Large oil sight glass

Makes visual inspection of oil level and condition easy!
Easy access to oil drain port on the end of the oil box.



7. Plug-in and pump

Integral IEC connector (available on most versions) allows easy connection to mains electric supply



APPLICATIONS

APPLICATIONS

	E2M0.7 - E2M1.5	E1M18 - E2M18	E2M28
Analytical instruments - GCMS	✓		
Analytical instruments - LCMS		✓	✓
Automotive		✓	✓
Beam lines and high energy physics		✓	✓
Centrifuges, ultra-high speed		✓	✓
Coating		✓	✓
Cryogenics		✓	✓
Degassing/curing - oil, epoxy resin		✓	✓
Distillation/extraction/filtration		✓	✓
Freeze drying		✓	✓
Furnaces		✓	✓
Gas bottle filling/emptying			✓
Gel drying		✓	✓
Glove boxes, ovens		✓	✓
Laboratory bench top vacuum	✓	✓	✓
Lasers, gas recovery and re-circulation			✓
Leak detectors, Helium	✓	✓	✓
Load locks and transfer chambers		✓	✓
Refrigeration manufacture		✓	✓
Research and development	✓	✓	✓
Rotary, centrifugal evaporators		✓	✓
Scanning electron microscopes - SEM	✓	✓	
SEM/FIB (Ion beam repair)		✓	
Solvent recovery		✓	✓
Surface science instruments		✓	✓
Turbomolecular backing pumps	✓	✓	✓

TECHNICAL DATA

VACUUM DATA

	Hz	Units	E2M0.7	E2M1.5	E1M18	E2M18	E2M28
Peak pumping speed	50	m ³ h ⁻¹	0.75	1.6	17	17	27.5
	60	cfm	0.5	1.2	12.1	12.1	19.5
Ultimate pressure w/o gas ballast	50	mbar	3.0x10 ⁻³	3.0x10 ⁻³	3x10 ⁻²	1x10 ⁻³	1x10 ⁻³
	60	Torr	2.3x10 ⁻³	2.3x10 ⁻³	2.2x10 ⁻²	7.5x10 ⁻⁴	7.5x10 ⁻⁴
Ultimate pressure with gas ballast	50	mbar	2x10 ⁻¹	2.5x10 ⁻²	6.5x10 ⁻¹	1.5x10 ⁻²	1.5x10 ⁻²
	60	Torr	1.5x10 ⁻¹	1.9x10 ⁻²	4.8x10 ⁻¹	1.1x10 ⁻²	1.1x10 ⁻²
Ultimate pressure with Fomblin®	50	mbar	n/a	n/a	3x10 ⁻¹	1x10 ⁻²	1x10 ⁻²
	60	Torr	n/a	n/a	2.3x10 ⁻¹	7.5x10 ⁻³	7.5x10 ⁻³
Water vapour tolerance		mbar	15	15	50	20	30
		Torr	11	11	38	15	23
Water vapour capacity		g/h	8	16	650	300	700

MOTOR DATA

	Hz	Units	E2M0.7	E2M1.5	E1M18	E2M18	E2M28
Motor power	50	kW	0.09	0.16	0.55	0.55	0.75
	60	kW	0.09	0.16	0.75	0.75	0.90
Nominal rotation speed	50	rpm	1400	2800	1440	1440	1440
	60	rpm	1700	3400	1720	1720	1720
Power connector (*)			IEC EN60320 C13	IEC EN60320 C13	IEC EN60320 C19	IEC EN60320 C19	IEC EN60320 C19

(*) pumps listed with IEC connector only

PHYSICAL DATA

	Units	E2M0.7	E2M1.5	E1M18	E2M18	E2M28
Weight	lb	22	22	82	86	97
	kg	10	10	37	39	44
Oil type (recommended)		Ultragrade performance 15			Ultragrade performance 19	
Oil capacity (maximum)	litre	0.28	0.28	1.4	1.05	1.5
Oil capacity (minimum)	litre	0.2	0.2	0.9	0.75	1.2
Inlet flange		NW10	NW10	NW25	NW25	NW25
Exhaust flange ⁽¹⁾		Nozzle 11mm external \varnothing removable from 3/4 in BSP tapped hole			Nozzle 15mm external diameter removable from 3/4 in BSP tapped hole	
Operating temperature range	°C	12-40	12-40	13-40	13-40	13-40
Noise level at 50Hz	dB(A)	43	54	57	57	57
Noise with acoustic enclosure ⁽²⁾	dB(A)	36	47	50	50	50

(1) PFPE variants are supplied with NW25 outlet connection

(2) approx. noise reduction 7 dB(A)

PERFORMANCE CURVES

E2M0.7 and E2M1.5 - 50Hz

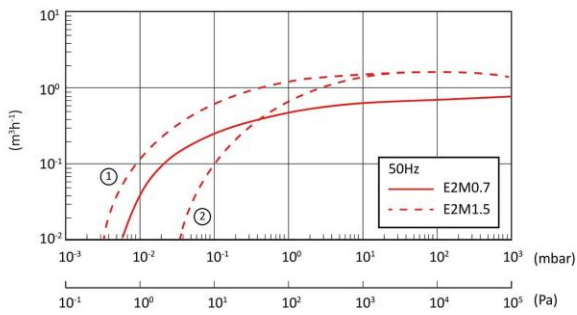

E2M0.7 and E2M1.5 - 60Hz

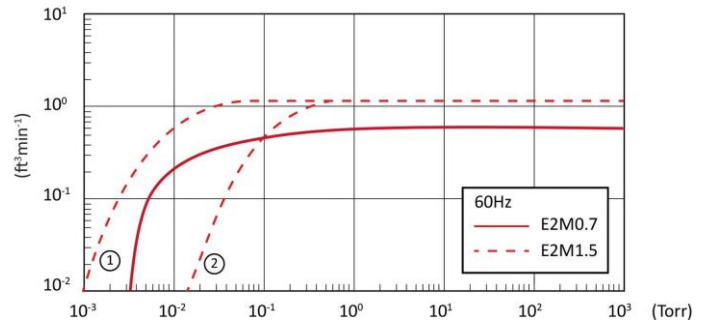

E1M18 and E2M18 - 50Hz

① WITHOUT GAS BALLAST
② WITH GAS BALLAST

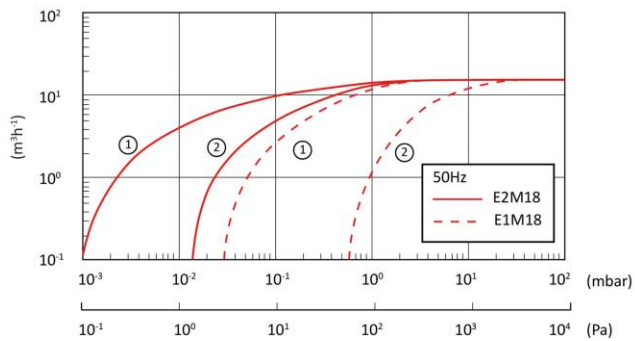

E1M18 and E2M18 - 60Hz

① WITHOUT GAS BALLAST
② WITH GAS BALLAST

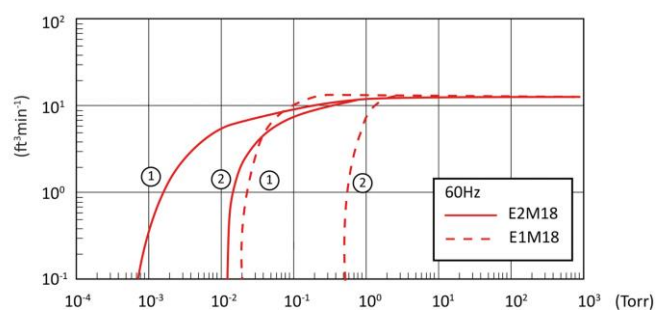

E2M28 - 50Hz

① WITHOUT GAS BALLAST
② WITH GAS BALLAST

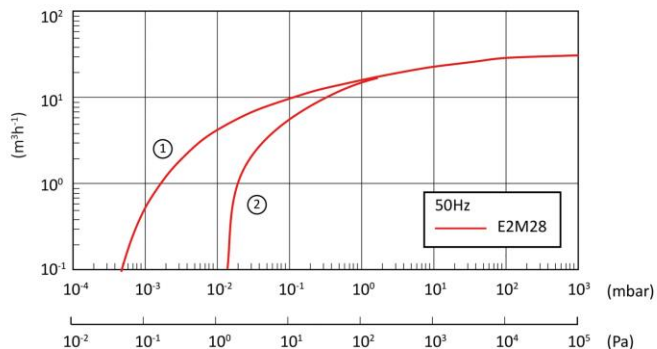

E2M28 - 60Hz

① WITHOUT GAS BALLAST
② WITH GAS BALLAST

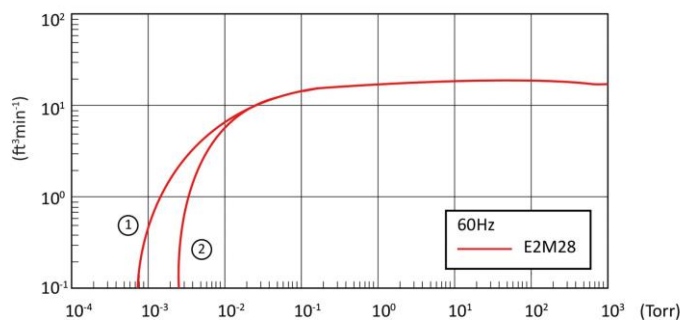

DIMENSIONS

E2M0.7 and E2M1.5

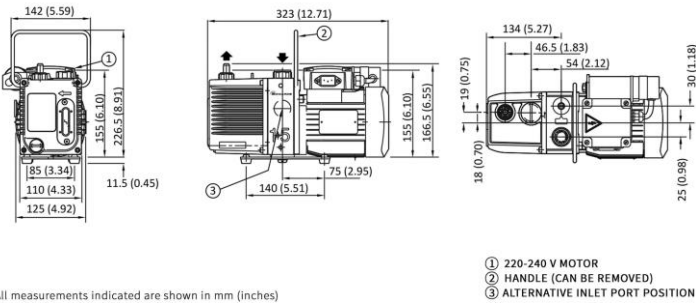

All measurements indicated are shown in mm (inches)

E1M18 one stage - E2M18 two stage dimensions

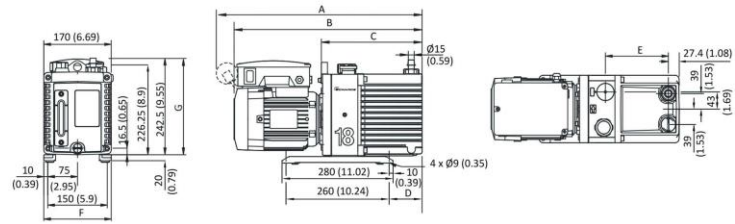

All measurements indicated are shown in mm (inches)

E2M28

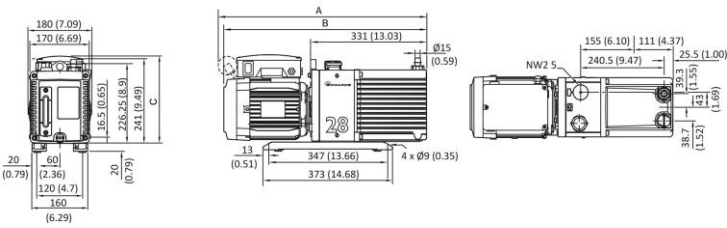

E1M18 one stage - E2M18 two stage dimensions

Ordering no.	A	B	C	D	E	F	G
A34310905, A34310925	-	474	246	83	159	172	217
A34315904	518	474	246	83	159	172	241
A34317984	-	504	246	83	159	172	251
A36310905, A36310925	-	520	294	131	207	172	217
A36315904	564	520	294	131	207	172	241
A36317984	-	520	294	131	207	172	251

E2M28

Ordering No.	A	B	C
A37315904	609	584	251
A37317984	-	584	251
A37333940	-	625	229

ORDERING INFORMATION

E2M0.7 / E2M1.5

Product description	Order No.
E2M0.7 200-230V, 1-ph, 50/60Hz, IEC 60320 connector	A37141919
E2M0.7 100-120V, 1-ph, 50/60Hz, IEC 60320 connector	A37141902
E2M1.5 200-230V, 1-ph, 50/60Hz, IEC 60320 connector	A37132919
E2M1.5 100-120V, 1-ph, 50/60Hz, IEC 60320 connector	A37132902
E2M1.5 interstage 200-230V, 1-ph, 50/60Hz, IEC 60320 connector	A37104919
E2M1.5 interstage 100-120V, 1-ph, 50/60Hz, IEC 60320 connector	A37104902

Each EM pump is supplied with Ultragrade performance 15 oil, O ring and centering ring, two Allen keys and spare seals for oil drain and filter plugs.

E1M18 / E2M18

Product description	Order No.
E1M18 380-415V, 50Hz 460V, 60Hz, 3-ph IE2	A34310905
E1M18 200-220V 50Hz 200-230V 60Hz, 3-ph IE2	A34310925
E1M18 100/200V, 1-ph, 50Hz or 100-105/200-210V, 1-ph, 60Hz factory set to 200V	A34315904
E1M18 115/200-230V, 1-ph, 50/60Hz with IEC60320 connector, factory set to 230V	A34317984
E1M18 FX 115/200-230V, 1-ph, 50/60Hz with IEC60320 connector, factory set to 230V	A34325984
E2M18 380-415V, 50Hz 460V, 60Hz, 3-ph IE2	A36310905
E2M18 200-220V 50Hz 200-230V 60Hz, 3-ph IE2	A36310925
E2M18 100/200V, 1-ph, 50Hz or 100-105/200-210V, 1-ph, 60Hz factory set to 200V	A36315904
E2M18 115/200-230V, 1-ph, 50/60Hz with IEC60320 connector, factory set to 230V	A36317984
E2M18FX 380-415V, 50Hz 460V, 60Hz, 3-ph IE2	A36321905
E2M18FX 200-220V 50Hz 200-230V 60Hz, 3-ph IE2	A36321925
E2M18 FX 100/200V, 1-ph, 50Hz or 100-105/200-210V, 1-ph, 60Hz factory set to 200V	A36325904

E1M18 / E2M18

Product description	Order No.
E2M18 FX 115/200-230V, 1-ph, 50/60Hz with IEC60320 connector, factory set to 230V	A36325984

Each EM pump is supplied with Ultragrade performance 19 oil, O ring and centering ring, two Allen keys and spare seals for oil drain and filter plugs.
For PFPE prepared FX pumps Fomblin® to be ordered separately.
3-phase and Japanese 100/200V motor to be hard wired.

E2M28

Product description	Order No.
E2M28 115/200-230 V, 1-ph, 50/60 Hz with IEC60320 connector, factory set to 230V	A37317984
E2M28 HC IE3 EU/US 50/60Hz, 380-400V 3-ph, 50Hz or 230/460V 3-ph, 60Hz	A37333940
E2M28 HC IE3 Asia 50/60Hz, 200V 3-ph, 50/60Hz or 380V 3-ph, 60Hz	A37333934
E2M28 100/200V, 1-ph, 50Hz or 100-105/200-210V, 1-ph, 60Hz factory set to 200V	A37315904
E2M28 FX IE3 EU/US 50/60Hz, 380-400V 3-ph, 50Hz or 230/460V 3-ph, 60Hz	A37343940
E2M28 FX IE3 Asia 50/60Hz, 200V 3-ph, 50/60Hz or 380V 3-ph, 60Hz	A37343934
E2M28 FX 115/200-230V, 1-ph, 50/60Hz with IEC60320 connector, factory set to 230V	A37325984

Each EM pump is supplied with Ultragrade performance 19 oil, O ring and centering ring, two Allen keys and spare seals for oil drain and filter plugs.
For PFPE prepared FX pumps Fomblin® to be ordered separately.
3-phase and Japanese 100/200V motor to be hard wired.

Accessories and spares E2M0.7 / E2M1.5

Product description	Order No.
EMF3 mist filter	A46220000
2m electrical supply cable for 1-ph pumps, UK, Three-pin plug	A50505000
2m electrical supply cable for 1-ph pumps, North European plug	A50506000
2m electrical supply cable for 1-ph pumps, North America/Japan plug	A50507000
2m electrical supply cable for 1-ph pumps, no plug	A50508000
Ultragrade 15 Oil 1 litre	H11026015
Clean and overhaul kit E2M0.7/1.5/2.5	A37101131
Spares kit blade E2M0.7/1.5	A37101132
Spares kit blade E2M2.5	A37601132
NW10 centring nitrile S/S pack 1	C10511396
NW10 O ring viton pack 5	H02124032
NW10 x 3/8 inch BSP adapter	A23908064

Accessories and spares E1M18 / E2M18 / E2M28

Product description	Order No.
EMF20 mist filter (suitable for E2M28 on low throughput applications)	A46229000
MF30 mist filter	A46233000
2m electrical supply cable for 1-ph pumps, UK, three-pin plug	A50505003
2m electrical supply cable for 1-ph pumps, North European plug	A50506003
2m electrical supply cable for 1-ph pumps, North America/Japan plug	A50507003
2m electrical supply cable for 1-ph pumps, no plug	A50508003
Ultragrade 19 oil 1 litre	H11025015
Fomblin YVAC 06/6 fluid 1 kg (532 ml)	H11301019
KRYTOX 1506 1 kg (1 kg PFPE fluid is approx. 0.5 litres)	H11307018
Clean and overhaul kit E1M18/E2M18 (suitable for use with hydrocarbon and PFPE prepared pumps)	A36301131
Spares kit blade E1M18	A34301041
Spares kit blade E2M18	A36301020
NW25 to 28mm bore tube adaptor	C10520201
¾ inch BSP to NW25 outlet adaptor	C10501414
E2M28 clean and overhaul kit (suitable for use with hydrocarbon and PFPE prepared pumps)	A37301131
Blade kit E2M28/30	A37301135
Acoustic enclosure 110-120V	NRD317000
Acoustic enclosure 200-240V	NRD318000

Official Distributor in Australia



EZZI VISION
Vacuum and Thin Film Technology

CONTACT US

T: 1800 GO EZZI
 E: sales@ezzivision.com.au
 W: ezzivision.com.au

VIC: 13/62 Ramset Drive, Chirnside Park,
 VIC 3116, Australia
NSW: Unit 1, 80 O'Riordan St, Alexandria,
 NSW 2015, Australia
WA: Unit 11, 24 Baile Road, Canning Vale,
 WA 6155 Australia



3601 0062 01 - August 2022. All rights reserved.
Edwards and the Edwards logo are trademarks of
Edwards Limited. Whilst we make every effort to ensure
that we accurately describe our products and services,
we give no guarantee as to the accuracy or
completeness of any information. Edwards Ltd,
registered in England and Wales No. 6124750,
registered office: Innovation Drive, Burgess Hill, West
Sussex, RH15 9TW, UK.