

RV OIL SEALED ROTARY VANE PUMPS





PERFORMANCE YOU CAN RELY ON

THE RV SERIES IS THE ULTIMATE RANGE OF SMALL OIL SEALED ROTARY VANE PUMPS

The result of many years' experience and a clean sheet design programme, with over 400,000 produced, these rugged vacuum pumps offer an excellent ultimate vacuum with good pumping speeds as well as superior vapour handling capabilities and quiet operation.

Mode selector and two position gas ballast

Configure your pump to meet your vacuum needs

High vapour handling

Flexibility to meet process needs

Designed for easy maintenance

Standard kits available for routine maintenance with simple tools

Fast acting, automatic inlet valve providing suck-back protection

Helps to protect process and systems

Quiet running

Better work environment

Superior oil lubrication

High reliability through positive pressure oil lubrication and generous oil pathways



APPLICATIONS

You can be assured Edwards has the application expertise and the RV pump or integrated system solution to meet your needs.



— Mass spectrometry

GCMS, LCMS, ICPMS, MALDI-TOF, RGA, surface science, leak detectors

— High energy physics

Beam lines, accelerators, mobile pump carts, turbomolecular pump backing, laser evacuation





— Electron microscopy

TEM, SEM, sample coaters

— Industrial

Glove boxes, coating systems, freeze drying, gas bottle filling/emptying, refrigeration system manufacture, degassing/curing (oil, epoxy resin)



— Chemical and sample preparation

Gel dryers, glove boxes, rotary evaporators, concentrators, distillation/extraction/filtration

Research and development

Chamber evacuation, coating systems,
turbomolecular pump backing

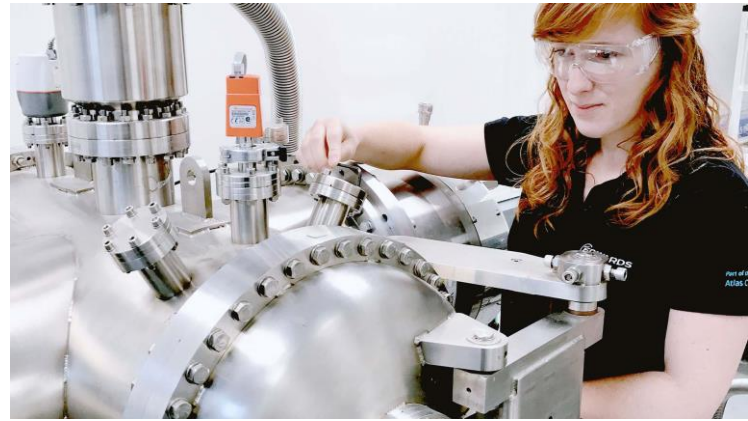

FEATURES AND BENEFITS





1. Gas ballast

Two position gas ballast allows either 60 g/hr or 220 g/hr (290 g/hr on RV12) of water vapour to be handled. This can be combined with an oil return accessory and an oil mist filter to enable continuous pumping with no loss of lubrication. Gas ballast can be automated by fitting the optional solenoid operated gas ballast valve.



2. Motor

Wide range single phase motor with an external switch to change the voltage from high to low volts. 3 phase motor options meet the requirements of the IE2 efficiency rating. For special applications, pumps with flameproof ATEX approved motors are available.

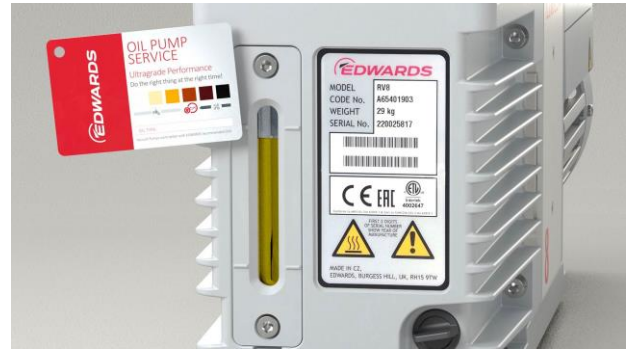

3. Oil

Edwards RV pumps are supplied with an initial charge of ULTRAGRADE™ Performance 19 oil. This premium quality oil has been specifically formulated with a unique package of additives to give the best vacuum performance of any mineral oil. As such it combines an extremely tightly controlled vapour pressure with a high resistance to oxidation for a long life. For oxygen rich applications PFPE prepared pumps are also available. Fomblin® must be purchased separately for PFPE prepared pumps.



4. Inlet

Best in class anti-suckback protection

- Smooth controlled opening by oil pressure to eliminate pressure surges
 - Rapid closing within 0.4 seconds of pump stopping
- All Edwards RV pumps are supplied with an inlet seal and integrated inlet mesh filter.



5. Mode switch

The unique mode selector switch means that one pump fits all, so you only need one model for both high throughput and high vacuum applications. In high throughput mode the selector switch increases the oil flow to the high vacuum stage allowing the pump to operate continuously with high inlet pressures without any wear or loss of lubrication.



6. Designed for easy maintenance

- One size hex-head wrench to dismantle all parts
- All parts self-aligning so no jigs or special assemblies required
- Polymer blades with no springs or pins for easier assembly and greater reliability
- Shaft seals can be replaced from the motor side without dismantling the pump mechanism
- No O-rings between the slices for easier assembly



7. No customer wiring

Integral IEC connector allows easy connection to mains electric supply for single phase standard motor pumps.

DIMENSIONS

Note: Single phase pumps diagrams are shown below - 3 phase pumps look different but share the same dimensions.

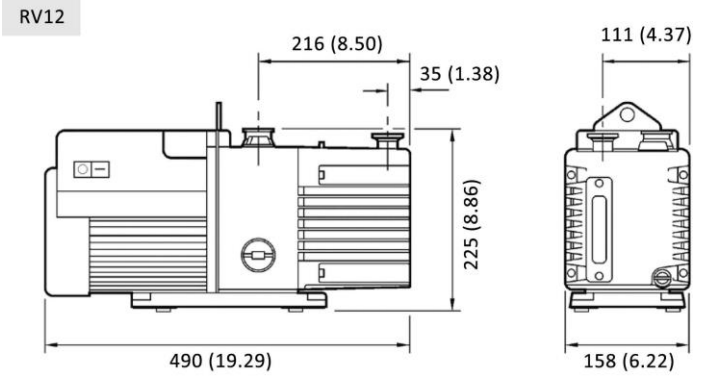
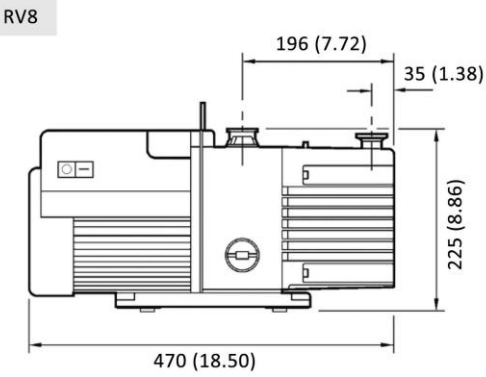
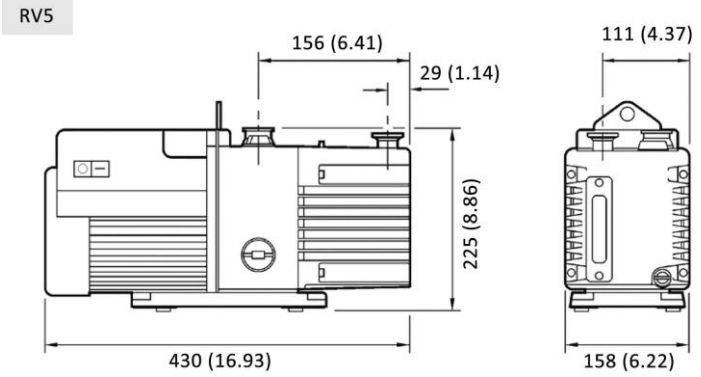
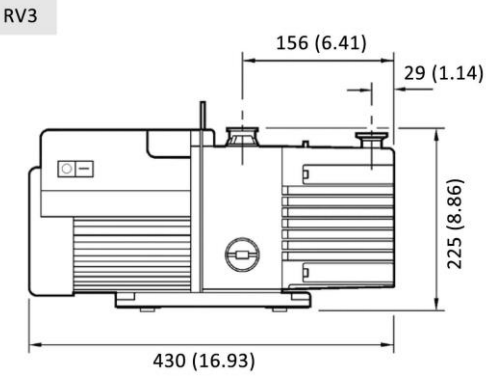



TECHNICAL DATA

Performance data

	Hz	Units	RV3	RV5	RV8	RV12
Peak pumping speed	60	cfm	2.3	3.7	5.9	8.4
	50	m ³ /h	3.3	5.1	8.5	12
Ultimate pressure (Total)	60	Torr	1.5 x 10 ⁻³ (1.5 x 10 ⁻² with Fomblin®)			
	50	mbar	2.0 x 10 ⁻³ (2.0 x 10 ⁻² with Fomblin®)			
Ultimate pressure GB I (Total)	50/60	Torr	2.3 x 10 ⁻²			
		mbar	3.0 x 10 ⁻²			
Ultimate pressure GB II (Total)	50/60	Torr	9.1 x 10 ⁻²	7.5 x 10 ⁻²	4.6 x 10 ⁻²	4.6 x 10 ⁻²
		mbar	1.2 x 10 ⁻¹	1 x 10 ⁻¹	6.0 x 10 ⁻²	6.0 x 10 ⁻²
Ultimate pressure high throughput mode	50/60	Torr	2.3 x 10 ⁻²			
		mbar	3.0 x 10 ⁻²			
Water vapour tolerance		Torr	60	38	28.5	24
		mbar	80	50	38	32
Water vapour capacity - GB I		g/h	60	60	60	60
Water vapour capacity - GB II		g/h	220	220	220	290

Motor data

	Hz	Units	RV3	RV5	RV8	RV12
Motor rating 1 phase (nominal) (W)	60	W	550			
	50	W	450			
Motor rating 3 phase (W)	60	W	300	300	550	550
	50	W	250	250	450	450
Nominal rotation speed (rpm)	60	rpm	1800			
	50	rpm	1500			

Physical data

	Units	RV3	RV5	RV8	RV12
Weight	lb	55	55	61.6	63.8
	kg	25	25	28	29
Oil capacity	litres	0.7	0.7	0.75	1
Oil type (ULTRAGRADE™ Performance)				19	
Inlet flange				NW25	
Exhaust flange				NW25	
Noise level @ 50 Hz	dB(A)			48	
Noise level (with Acoustic Enclosure) @ 50 Hz	dB(A)			41	
Operating temperature range	°C			12 to 40	

ORDERING INFORMATION

Products

Product description	Order No.	Order No.
	Ultragrade Oil	PFPE prepared*
RV3		
115/230V, 1 phase 50/60Hz set to 230V	A65201903	A65209903
100/200V, 1 phase 50/60Hz set to 200V	A65201904	A65209904
200-220/380-415V, 50Hz 200-230/460V, 60Hz, 3 phase IE2	A65201905	A65209905
115/230V, 1 phase 50/60Hz set to 115V	A65201906	A65209906
100/200V, 1 phase 50/60Hz set to 100V	A65201907	N/A
RV5		
115/230V, 1 phase 50/60Hz set to 230V	A65301903	A65309903
100/200V, 1 phase 50/60Hz set to 200V	A65301904	A65309904
200-220/380-415V, 50Hz 200-230/460V, 60Hz, 3 phase IE2	A65301905	A65309905
115/230V, 1 phase 50/60Hz set to 115V	A65301906	A65309906
100/200V, 1 phase 50/60Hz set to 100V	A65301907	N/A
RV8		
115/230V, 1 phase 50/60Hz set to 230V	A65401903	A65409903
100/200V, 1 phase 50/60Hz set to 200V	A65401904	A65409904
380-415V, 50Hz 460V, 60Hz, 3 phase IE2	A65422905	A65429905
200-208V, 50Hz 200-230V, 60Hz, 3 phase IE2	A65422925	A65429925
115/230V, 1 phase 50/60Hz set to 115V	A65401906	A65409906
100/200V, 1 phase 50/60Hz set to 100V	A65401907	N/A
RV12		
115/230V, 1 phase 50/60Hz set to 230V	A65501903	A65509903
100/200V, 1 phase 50/60Hz set to 200V	A65501904	A65509904
380-415V, 50Hz 460V, 60Hz, 3 phase IE2	A65522905	A65529905

Products

Product description	Order No.	Order No.
	Ultragrade Oil	PFPE prepared*
200-208V, 50Hz 200-230V, 60Hz, 3 phase IE2	A65522925	A65529925
115/230V, 1 phase 50/60Hz set to 115V	A65501906	A65509906
100/200V, 1 phase 50/60Hz set to 100V	A65501907	N/A

* PFPE fluid (Fomblin®) not included: to be purchased separately for PFPE Prepared pumps. 1kg = 532 ml.

Accessories

	Product description	Order No.
Cord sets for single phase IEC pumps	UK, three pin plug	A50505000
	North European plug	A50506000
	North American plug	A50507000
	No plug	A50508000
Oil	ULTRAGRADE™ Performance 19, 1 litre bottle	H11025015
	Fomblin® YVAC06/6 1kg (532 ml)	H11301019
	ULTRAGRADE™ Performance 19 oil 4 litre	H11025013
Inlet accessories	Foreline trap - FL20K	A13305000
Outlet accessories	Oil mist filter - EMF10	A46226000
	Oil mist filter - EMF20	A46229000
Oil return kits	Clean application (no gas ballast)	A50419000
	Adjustable gas ballast	A50523000
Vibration isolators		A24801404
Spares kits	Clean and overhaul kit	A65201131
Acoustic enclosure	Low volts 110-120V	NRD317000
Acoustic enclosure	High volts 200-240V	NRD318000

Pumps fitted with ATEX approved motors are available, contact Edwards for details

Pumps are supplied with initial charge of ULTRAGRADE™ Performance oil

Official Distributor in Australia



EZZI VISION

Vacuum and Thin Film Technology

CONTACT US

T: 1800 GO EZZI

E: sales@ezzivision.com.au

W: ezzivision.com.au

VIC: 13/62 Ramset Drive, Chirnside Park, VIC 3116, Australia

NSW: Unit 1, 80 O'Riordan St, Alexandria, NSW 2015, Australia

WA: Unit 11, 24 Baile Road, Canning Vale, WA 6155 Australia



3601 0072 01 - August 2022. All rights reserved.
Edwards and the Edwards logo are trademarks of
Edwards Limited. Whilst we make every effort to ensure
that we accurately describe our products and services,
we give no guarantee as to the accuracy or
completeness of any information. Edwards Ltd,
registered in England and Wales No. 6124750,
registered office: Innovation Drive, Burgess Hill, West
Sussex, RH15 9TW, UK.