

Instruction Manual

E2M0.7 and E2M1.5 Rotary Vacuum Pumps

Description		Item Number
E2M0.7 (0.7 m ³ h ⁻¹ , 0.4 ft ³ min ⁻¹)	220-240 V, 50/60 Hz	A371-31-919
E2M0.7 (0.7 m ³ h ⁻¹ , 0.4 ft ³ min ⁻¹)	100-120 V, 50/60 Hz	A371-31-902
E2M1.5 (1.5 m ³ h ⁻¹ , 0.8 ft ³ min ⁻¹)	220-240 V, 50/60 Hz	A371-22-919
E2M1.5 (1.5 m ³ h ⁻¹ , 0.8 ft ³ min ⁻¹)	220-240 V, 50/60 Hz (Interstage)	A371-03-919
E2M1.5 (1.5 m ³ h ⁻¹ , 0.8 ft ³ min ⁻¹)	100-120 V, 50/60 Hz	A371-22-902
E2M1.5 (1.5 m ³ h ⁻¹ , 0.8 ft ³ min ⁻¹)	100-120 V, 50/60 Hz (Interstage)	A371-03-902



Official Distributor in Australia



EZZI VISION

Vacuum and Thin Film Technology

CONTACT US

T: 1800 GO EZZI

E: sales@ezzivision.com.au

W: ezzivision.com.au

VIC: 13/62 Ramset Drive, Chirnside Park,
VIC 3116, Australia

NSW: Unit 1, 80 O'Riordan St, Alexandria,
NSW 2015, Australia

WA: Unit 11, 24 Baile Road, Canning Vale,
WA 6155 Australia

Why Choose Ezzi Vision?

'Partner with excellence in Vacuum Technology, opt for Ezzi Vision'

Decades of Expertise: With 30+ years in the industry, Ezzi Vision is highly experienced in vacuum technology and its applications.

Quality Assurance: We ensure that every Edwards pump meets the highest standards of performance and reliability.

Innovative Solutions: Leading in technological advancements, we provide the latest Edwards pumps, known for their innovation and efficiency.

Customer-Centric: Ezzi Vision delivers personalized service and expert advice to meet your needs.

Nationwide: Ezzi Vision brings quality vacuum solutions to all of Australia.

After-Sales Support: We provide comprehensive support to maintain your equipment's longevity and efficiency.

Sustainable Practices: Our products at Ezzi Vision align with contemporary environmental standards, promoting sustainable practices in your business operations.

With Ezzi Vision propel your business forward using state-of-the-art technology and steadfast support.



Declaration of Conformity

We, Edwards Limited,
Crawley Business Quarter,
Manor Royal,
Crawley,
West Sussex, RH10 9LW, UK

declare under our sole responsibility, as manufacturer and person within the EU authorised to assemble the technical file, that the product(s)

E2M0.7 and E2M1.5 Rotary Vacuum Pumps without IEC connector

A371-31-919	A371-22-919	A371-13-930	A371-31-902
A371-13-988	A371-22-902	A371-03-919	

to which this declaration relates is in conformity with the following standard(s) or other normative document(s)

EN61010-1:2010*	Safety Requirements for Electrical Equipment for Measurement, Control and Laboratory Use. General Requirements
EN1012-2:1996+A1:2009	Compressors and Vacuum Pumps. Safety Requirements. Vacuum Pumps
EN60034-1:2010	Rotating electrical machines. Rating and performance
CAN/CSA-C22.2 No 77:2014#	Motors with inherent overheating protection
CAN/CSA-C22.2 No 100:2014#	Motors and Generators
EN50581:2012	Technical Documentation for the Assessment of Electrical and Electronic Products with respect to the Restriction of Hazardous Substances

* 1-phase pumps only. *The pumps comply with EN 61010-1 when installed in accordance with the instruction manual supplied with the pumps.*

100/120V pumps only. *Canadian Standards Association.*

and fulfils all the relevant provisions of

2006/42/EC	Machinery Directive
2014/35/EU	Low Voltage Directive
2011/65/EU	Restriction of Certain Hazardous Substances (RoHS) Directive

Note: This declaration covers all product serial numbers from the date this Declaration was signed onwards.

Mr Peter Meares
Senior Technical Support Manager, General Vacuum

10.08.2015, Burgess Hill

Date and Place

This product has been manufactured under a quality management system certified to ISO 9001:2008

Contents

Section	Page
1	Introduction 1
1.1	Scope and definitions..... 1
1.2	ATEX directive implications..... 2
1.3	Description..... 4
1.4	Gas-ballast 4
2	Technical data 5
2.1	Operating and storage conditions..... 5
2.2	Performance 5
2.3	Mechanical data 6
2.4	Electrical data..... 6
2.5	Lubrication data..... 7
3	Installation 9
3.1	Safety..... 9
3.2	System design 9
3.3	Unpack and inspect..... 10
3.4	Locate the pump 10
3.5	Fill the pump with oil 10
3.6	Electrical installation..... 11
3.6.1	Connect the pump to your electrical supply 11
3.6.2	Check the direction of rotation 11
3.7	Connect the pump inlet..... 12
3.7.1	General requirements 12
3.7.2	Side inlet-port connection 13
3.8	Connect the pump outlet 13
3.9	Leak-test the system 13
4	Operation..... 15
4.1	ATEX directive implications..... 15
4.1.1	Introduction..... 15
4.1.2	Flammable/pyrophoric materials..... 15
4.1.3	Gas purges 16
4.2	Gas-ballast control..... 16
4.3	Start-up procedure 17
4.4	To achieve ultimate vacuum 17
4.5	To pump condensable vapours 18
4.6	To decontaminate the oil..... 18
4.7	Unattended operation 18
4.8	Shut-down..... 18
5	Maintenance 19
5.1	Safety information 19
5.2	Maintenance plan 19
5.3	Check the oil-level..... 20
5.4	Replace the oil 20
5.5	Inspect and clean the inlet-filter 21
5.6	Clean or replace the gas-ballast O-ring 21
5.7	Clean the motor fan-cover and enclosure 22
5.8	Clean and overhaul the pump 22

5.9	Fit new blades.....	22
5.10	Replace the capacitor and test the motor.....	22
5.11	Fault finding.....	22
6	Storage and disposal	25
6.1	Storage	25
6.2	Disposal	25
7	Service, spares and accessories	27
7.1	Introduction.....	27
7.2	Service	27
7.3	Spares	27
7.4	Accessories.....	28
7.4.1	Introduction.....	28
7.4.2	Inlet catchpot	28
7.4.3	Inlet dust filter	28
7.4.4	Inlet desiccant trap.....	28
7.4.5	Inlet chemical trap	28
7.4.6	Foreline trap.....	28
7.4.7	Outlet mist filter.....	30
7.4.8	Oil drain extension.....	30
7.4.9	Vibration isolators	30
7.4.10	Pump inlet or outlet NW25 adaptor	30
7.4.11	Solenoid operated gas-ballast control valve.....	30
7.4.12	Solenoid operated pipeline valve.....	30

For return of equipment, complete the HS Forms at the end of this manual.

Illustrations

Figure		Page
1	The E2M0.7 and E2M1.5 pump.....	3
2	Dimensions: mm (inches)	7
3	Electrical supply connection.....	12
4	Inlet-filter removal and replacement	21
5	Gas-ballast O-ring removal and replacement	22
6	Accessories.....	29

Tables

Table		Page
1	Operating and storage conditions.....	5
2	Performance data.....	5
3	Mechanical data.....	6
4	Electrical data.....	6
5	Lubrication data.....	7
6	Checklist of items.....	10
7	Maintenance plan.....	20
8	Fault finding.....	23
9	Spares Item Numbers.....	27
10	Accessories Item Numbers.....	28

Associated publications

Publication title

Publication number

Vacuum Pump and Vacuum System Safety

P400-40-100

This page has been intentionally left blank.

1 Introduction

1.1 Scope and definitions

This manual provides installation, operation and maintenance instructions for the Edwards E2M0.7, and E2M1.5 rotary vacuum pumps. You must use the pump as specified in this manual. Read this manual before you install and operate the pump.

Important safety information is highlighted as WARNING and CAUTION instructions; you must obey these instructions. The use of WARNINGS and CAUTIONS is defined below.



WARNING

Warnings are given where failure to observe the instruction could result in injury or death to people.

CAUTION

Cautions are given where failure to observe the instruction could result in damage to the equipment, associated equipment and process.

The units used throughout this manual conform to the SI international system of units of measurement. Equivalent values using imperial units of measurement are also included.

The following warning symbols are on the pump:



Warning - refer to accompanying documentation.



Warning - risk of electric shock.



Warning - hot surfaces.

1.2 ATEX directive implications



This equipment is designed to meet the requirements of Group II Category 3 equipment in accordance with Directive 94/9/EC of the European Parliament and the Council of 23rd March 1994 on the approximation of the laws of the Member States concerning equipment and protective systems intended for use in potentially explosive atmospheres. (The ATEX Directive)

The ATEX Category 3 applies in respect of potential ignition sources internal to the equipment. An ATEX Category has not been assigned in respect of potential ignition sources on the outside of the equipment as the equipment has not been designed for use where there is an external potentially explosive atmosphere.

There is no potential source of ignition within the pump during normal operation but there may be potential sources of ignition under conditions of predictable and rare malfunction as defined in the Directive. Accordingly, although the pump is designed to pump flammable materials and mixtures, operating procedures should ensure that under all normal and reasonably predictable conditions, these materials and mixtures are not within explosive limits. Category 3 is considered appropriate for the avoidance of ignition in the case of a rare malfunction which allows flammable materials or mixtures to pass through the pump while within their explosive limits.

When flammable or pyrophoric materials are present within the equipment you must:

- Not allow air to enter the equipment.
- Ensure that the system is leak tight.

For further information, please contact Edwards: refer to the Addresses page at the end of this manual for details.

Figure 1 - The E2M0.7 and E2M1.5 pump

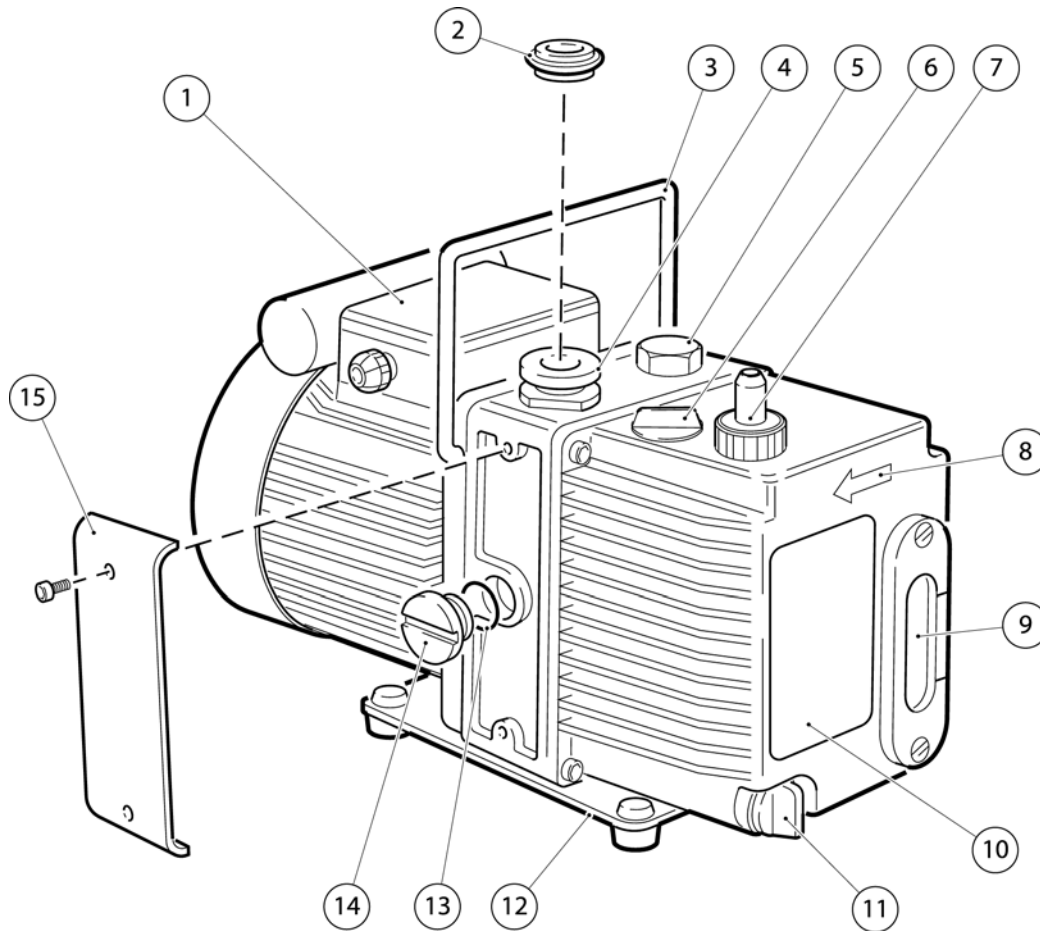

- | | |
|--|-------------------------------------|
| 1. Motor terminal box | 9. Oil sight-glass and bezel |
| 2. NW10 centring ring and O-ring (supplied) | 10. Pump identification label |
| 3. Handle (removable: refer to Section 3.4) | 11. Oil drain-plug |
| 4. NW10 inlet port (adaptor flange) | 12. Baseplate |
| 5. Gas-ballast control | 13. O-ring |
| 6. Oil filler-plug | 14. Blanking plug (side inlet-port) |
| 7. Outlet nozzle | 15. Removable side panel |
| 8. Pump/motor shaft rotation direction arrow | |

AS/0756/A

1.3 Description

The Edwards E2M0.7 and E2M1.5 pump is shown in [Figure 1](#). Refer to [Figure 1](#) for item numbers in brackets in the following descriptions.

The E2M0.7 and E2M1.5 pumps are two-stage, direct drive, sliding vane pumps. The pump is oil-sealed and designed for reliable, long-term operation. The pump is a free-standing unit. The drive is provided through a coupling by a single-phase motor.

The motor is totally enclosed and is cooled by the motor-cooling fan which directs air along the motor fins. The motors are fitted with a thermal overload device. When the motor is too hot, the thermal overload device switches off the pump. The thermal overload device has an automatic reset; when the motor cools down, the device resets and the motor will restart.

An oil pressure system lubricates the pump shaft bearing surfaces and rotor sealing faces. The pump has an oil distribution valve which prevents discharge of oil to the pump interior (suckback) after the pump stops. The pumping chambers are air-tight, so this arrangement prevents oil suckback unless the gas-ballast valve is open. For protection in this case, refer to [Section 1.4](#).

The level and condition of the oil in the oil box reservoir can be inspected through the sight-glass (9). An oil filler-plug (6) is fitted to the top of the oil box. An oil drain-plug (11) is fitted at the bottom of the oil box.

The pump has a carrying handle (3), inlet-port (4), outlet nozzle (7) and gas-ballast control (5). The pump is mounted on a steel baseplate (12) on rubber pads. Details of suitable vibration isolators and other recommended accessories are given in [Section 7.4](#).

1.4 Gas-ballast

To pump high vapour loads, gas-ballast is delivered into the pump to prevent condensation of the vapour carried by the pumped gases.

Air (or another gas) can be introduced into the low vacuum stage through the gas-ballast control. The gas-ballast control is a multi-turn valve that can be adjusted, as required, between closed and fully open.

2 Technical data

Note: To comply with EN61010 and CSA standards, the pump must be installed and used indoors, and within the operating conditions specified in Table 1.

2.1 Operating and storage conditions

Table 1 - Operating and storage conditions

Ambient temperature range (operation)	12 to 40°C (53.6 to 104°F)
Ambient temperature range (storage)	-30 to 70°C (-22 to 158°F)
Normal surface temperature of the pump-body*	50 to 70°C (122 to 158°F)
Maximum humidity (operation)	90% RH
Maximum altitude (operation)	2000 m (6561 ft)
Pollution degree	2
Installation category	II

* At ultimate vacuum, with ambient temperature of 20°C (68°F).

2.2 Performance

Note: Where total pressures are shown below, the measurements were taken using an untrapped total pressure capacitance diaphragm gauge on a header, as specified by Pneurop 6602.

Table 2 - Performance data

	E2M0.7	E2M1.5
Maximum displacement		
50 Hz electrical supply	0.9 m ³ h ⁻¹ (0.53 ft ³ min ⁻¹)	1.8 m ³ h ⁻¹ (1.06 ft ³ min ⁻¹)
60 Hz electrical supply	1.1 m ³ h ⁻¹ (0.65 ft ³ min ⁻¹)	2.2 m ³ h ⁻¹ (1.30 ft ³ min ⁻¹)
Maximum pumping speed - Pneurop		
50 Hz electrical supply	0.75 m ³ h ⁻¹ (0.44 ft ³ min ⁻¹)	1.6 m ³ h ⁻¹ (0.94 ft ³ min ⁻¹)
60 Hz electrical supply	0.95 m ³ h ⁻¹ (0.56 ft ³ min ⁻¹)	2.0 m ³ h ⁻¹ (1.18 ft ³ min ⁻¹)
Motor rotational speed		
50 Hz electrical supply	1400 r min ⁻¹	2800 r min ⁻¹
60 Hz electrical supply	1700 r min ⁻¹	3400 r min ⁻¹
Ultimate vacuum		
without gas-ballast (partial pressure)	7 x 10 ⁻⁴ mbar, 7 x 10 ⁻² Pa (5.2 x 10 ⁻⁴ Torr)	5 x 10 ⁻⁴ mbar, 5 x 10 ⁻² Pa (3.7 x 10 ⁻⁴ Torr)
without gas-ballast (total pressure)	3 x 10 ⁻³ mbar, 3 x 10 ⁻¹ Pa (2.2 x 10 ⁻³ Torr)	1.5 x 10 ⁻³ mbar, 1.5 x 10 ⁻¹ Pa (1.1 x 10 ⁻³ Torr)
with full gas-ballast (partial pressure)	2 x 10 ⁻¹ mbar, 2 x 10 ⁻¹ Pa (1.5 x 10 ⁻¹ Torr)	2.5 x 10 ⁻² mbar, 2.5 Pa (1.9 x 10 ⁻² Torr)
Maximum water vapour inlet pressure	15 mbar (11.2 Torr)	15 mbar (11.2 Torr)
Maximum water vapour pumping rate	8 g h ⁻¹	16 g h ⁻¹
Maximum permitted outlet pressure (at full pump throughput)	0.5 bar gauge 1.5 bar absolute 1.5 x 10 ⁵ Pa (21.75 psi)	0.5 bar gauge 1.5 bar absolute 1.5 x 10 ⁵ Pa (21.75 psi)

2.3 Mechanical data

Table 3 - Mechanical data

Approximate pump mass	10 kg (22 lbs)
Dimensions	Refer to Figure 2
Degree of protection (IEC34-5:1981)	IP54
Pump inlet port	NW10 (the flange can be removed from the $\frac{3}{8}$ inch BSP tapped hole)
Pump outlet port	11 mm external diameter nozzle (the nozzle can be removed from the $\frac{3}{8}$ inch BSP tapped hole)
Noise level at 1 metre	54 dB(A)

2.4 Electrical data

The motor start-up current is drawn for less than one second, therefore slow-blow fuses must be used to prevent unnecessary fuse failure when the pump starts. If the pump is used at temperatures lower than 12°C (53.6°F), the start-up current will be drawn for longer; this may cause the motor thermal overload device to open.

Table 4 - Electrical data

Continuous motor output rating					
E2M0.7		0.09 kW			
E2M1.5		0.16 kW			
Motor electrical supply					
E2M0.7		Single phase			
E2M1.5		Single phase			
Pump	Nominal supply (V)	Frequency (Hz)	Full load current (A)	Start-up current (A)	Maximum fuse rating (A)*
E2M0.7	110-115	50	1.8	5.7	10
	115-120	60	1.9	5.3	10
	220-240	50	1.0	2.8	6
	230-240	60	1.0	2.3	6
E2M1.5	110-115	50	3.1	12.0	10
	115-120	60	2.6	11.2	10
	220-240	50	1.4	5.5	6
	230-240	60	1.3	5.2	6

* Fuses should be EN60269 Section 2.2 or to BS 1362.

2.5 Lubrication data

Note: An Edwards Safety Data Sheet for Ultragrade 15 is available on request.

Table 5 - Lubrication data

Recommended oil*	Ultragrade 15
Maximum oil capacity	0.32 litre

* To operate the pump when the ambient temperature is outside the range specified in Section 2.1, or to optimise pump performance when you process condensable vapours, a different oil may be required.

Figure 2 - Dimensions: mm (inches)

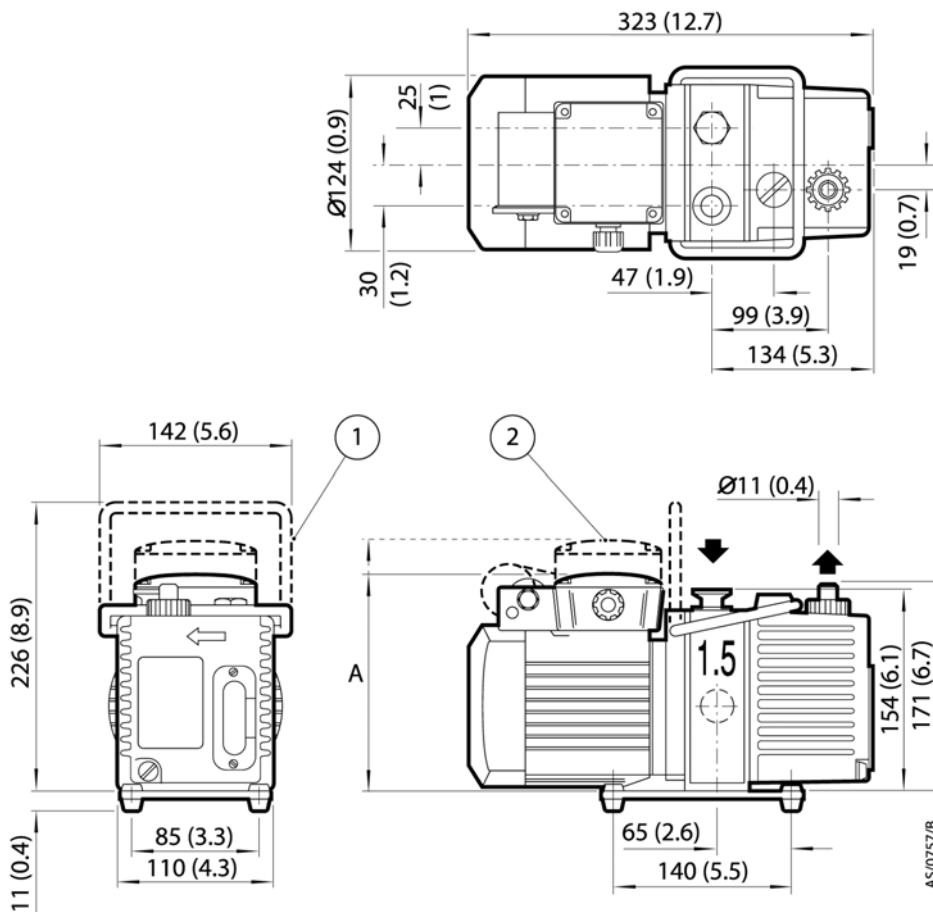

A. 160 (6.3) for 220/240 V motors, 189 (7.4) for 110/120 V motors

1. Handle (removable: refer to Section 3.4)
2. 110/120 V motor

This page has been intentionally left blank.

3 Installation

3.1 Safety



WARNING

If a hydrocarbon oil is used in this pump, do not use the pump to process oxygen in concentrations greater than 25% in volume. There is a risk of fire or explosion in the oil-box of the pump.



WARNING

Edwards recommend that the E2M0.7 or E2M1.5 pumps are not used to pump hazardous substances.

Obey the safety instructions in this Section and take note of appropriate precautions. If not, injury to people and damage to equipment can result.

Prevent any part of the human body from coming into contact with the vacuum.

You must ensure that the pump is suitable for your application, If you have any doubts as to the suitability of the pump for your application, refer to the Edwards guidelines on vacuum pump and vacuum system safety (see the Associated publication at the end of the contents list at the front of this manual).

A suitably trained and supervised technician must install your pump. Obey the safety instructions listed below when installing the pump, especially when connecting the pump into an existing system. Details of specific safety precautions are given at the appropriate point in the instructions.

- Wear the appropriate safety-clothing when in contact with contaminated components.
- Vent and purge the vacuum system before installation work is started.
- Ensure that the installation technician is familiar with the safety procedures that relate to the pump-oil and the products handled by the pumping system. Take suitable precautions to avoid the inhalation of oil mist and excessive skin contact with pump-oil, as prolonged exposure can be harmful.
- Disconnect the other components in the pumping system from the electrical supply so that they cannot be operated accidentally.

3.2 System design

Consider the following points when designing your pumping system:

- Use a suitable valve to isolate the pump from the vacuum system, if the pump needs to warm up before condensable vapours are pumped, or if the vacuum needs to be maintained when the pump is switched off.
- Avoid high levels of heat input to the pump from the process gases, otherwise the pump may overheat and seize, and cause the motor thermal overload device to open.
- If the pump is used in a high ambient temperature and have a high gas throughput, the temperature of the pump-body may exceed 70°C (158°F) and suitable guards must be fitted to prevent contact with hot surfaces.
- Make sure that the exhaust pipeline cannot become blocked. If an exhaust-isolation valve is fitted, make sure the pump cannot be operated with the valve closed.
- Provide for a purge of inert gas when the pumping system is shut down, to dilute dangerous gases to safe concentrations. A suitable gas-ballast control valve for introduction of purge gas into the pump is available as an accessory (refer to [Section 7.4.11](#)).

3.3 Unpack and inspect

1. Remove all packing materials and protective covers and check the pump. If the pump is damaged, notify your supplier and the carrier in writing within three days; state the Item Number of the pump together with your order number and your supplier's invoice number. Retain all packing materials for inspection. Do not use the pump if it is damaged.
2. Check that your package contains the items listed in [Table 6](#). If any of these items is missing, notify your supplier within three days.

If the pump is not to be used immediately, replace the protective covers. Store the pump in suitable conditions, as described in [Section 6.1](#).

Table 6 - Checklist of items

Quantity	Description	Check (☐)
1	Rotary vacuum pump	<input type="checkbox"/>
(1)	Fitting pack containing the following:	
1	Hexagon wrench, 4 mm	<input type="checkbox"/>
1	Hexagon wrench, 6 mm	<input type="checkbox"/>
1	NW10 centring ring	<input type="checkbox"/>
1	O-ring for centring	<input type="checkbox"/>
1	O-ring for outlet port	<input type="checkbox"/>

3.4 Locate the pump

The pump can be either free-standing on its baseplate which is fitted with rubber pads; fixed by four fixing bolt holes in the baseplate; or used with vibration isolators. For the location of the fixing holes in the baseplate, refer to [Figure 2](#). Provide a firm, level platform for the pump.

Locate the pump so that the oil level sight-glass is visible and the oil filler-plug, oil drain-plug, mode selector and gas-ballast control are accessible.

If the pump is part of a permanent installation the handle can be removed to make the pump more compact. To remove the handle, cut the handle in half, then remove the two halves from the pump.

If the pump will be located inside an enclosure, ensure that there is adequate ventilation at both ends of the pump, so that the ambient temperature around the pump does not exceed 40°C. There must be a minimum space of 25 mm between the pump and enclosure walls.

3.5 Fill the pump with oil

Fill the pump with oil as described below. Refer to [Figure 1](#) for the item numbers in brackets.

1. Remove the oil filler-plug (6).
2. Pour oil into the pump until the oil-level just reaches the MAX mark on the bezel at the top of the sight-glass (9). If the oil-level goes above the MAX mark, remove the drain-plug (11) and drain the excess oil from the pump.
3. After a few minutes, recheck the oil-level. If the oil-level is now below the MAX mark, pour more oil into the pump.
4. Refit the oil filler-plug. Tighten the plug firmly by hand. Do not overtighten.

3.6 Electrical installation



WARNING

Ensure that the electrical installation of the pump conforms with your local and national safety requirements. It must be connected to a suitably fused and protected electrical supply and a suitable earth (ground) point.

Note: The following instructions for connecting the pump to an electrical supply are not applicable to pumps fitted with an integral (non-detachable) electrical supply cable.

3.6.1 Connect the pump to your electrical supply

Note: The pump will restart automatically when the electrical supply is restored after an interruption and when the pump cools after it has overheated. If you do not want the pump to restart automatically, use electrical control equipment that must be reset manually.

Ensure that your electrical supply voltage corresponds with the voltage specified on the motor data plate. Refer to [Section 2.4](#) for fuse recommendations, and refer to [Figure 3](#) for a schematic of the electrical connections. The diameter of the outer sheath of the supply cable must be within the range 5 to 8 mm. The supply cable must conform in size and colour coding with your local and national electrical installation regulations. The temperature rating of the cable must be 70°C (158°F) or greater.

1. Remove the cover from the motor terminal box ([Figure 1](#), item 1). Take out the plastic cable gland which is supplied loose inside.
2. Screw the plastic cable gland into the hole in the side of the motor terminal box. Using a tool this should be tightened to a torque of 3.75 Nm.
3. Thread the supply cables through the gland and connect to the appropriate terminals, as shown in [Figure 3](#). The earth (ground) terminal connection must be tightened to a torque of 2.13 to 2.87 Nm (1.57 to 2.11 lbf ft).
4. Tighten the dome shaped nut on the cable gland until the outer sheath of the cable is firmly gripped. Using a tool this should be tightened to a torque of 2.5 Nm, do not overtighten.
5. Check that the cable connections are correct, then replace the cover on the motor terminal box.

3.6.2 Check the direction of rotation

CAUTION

Ensure that the pump-motor rotates in the correct direction. If it does not, the pump and your vacuum system can become pressurised.

Refer to [Figure 1](#).

1. Watch the motor-cooling fan through the fan cover on the end of the motor.
2. Switch on the electrical supply to the motor for a few seconds.
3. Check that the motor-cooling fan rotates in the direction shown by the arrow (8) on the end of the oil box. If the rotation direction is incorrect, immediately switch off the electrical supply, check the wiring to the pump motor and correct as necessary.

Figure 3 - Electrical supply connection

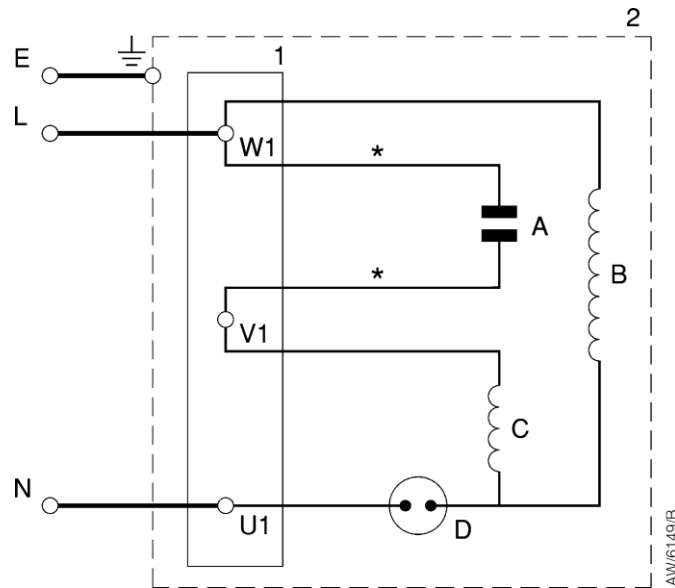

- | | |
|----------------------------|----------------------------|
| A. Capacitor | ⊥ Earth (ground) connector |
| B. Main motor winding | 1. Motor terminals |
| C. Auxiliary motor winding | 2. Motor terminal box |
| D. Thermal protector | |
| E. Earth (ground) | |
| L. Live | |
| N. Neutral | * Colour not significant |

3.7 Connect the pump inlet

3.7.1 General requirements

To connect the pump to the vacuum system, use either the inlet-port on the top of the pump (Figure 1, item 4) or the inlet-port on the side of the pump (Figure 1, item 14). Refer to the procedure in Section 3.7.2 for instructions on using the side inlet port.

When using either the top or the side inlet-port, it is possible to:

- Connect to the NW10 flange supplied on the pump; use the centring ring and O-ring supplied.
- Remove the NW10 flange and connect to the $\frac{3}{8}$ inch BSP threaded hole.
- Remove the NW10 flange and replace it with a NW25 flange adaptor (available as an optional accessory, see Section 7.4) and then connect to the NW25 flange.

Take note of the following information when connecting the pump to the vacuum system. Refer to Section 7.4 for details of the accessories mentioned below.

- For optimum pumping speeds, ensure that the pipeline connected to the inlet-port is as short as possible and has an internal diameter not less than the inlet-port diameter.
- Support the vacuum pipelines to prevent loading of the coupling-joints.

- If necessary, incorporate flexible bellows in the system pipelines to reduce the transmission of vibration and to prevent loading of coupling-joints. If using flexible bellows, ensure that the bellows used have a maximum pressure rating that is greater than the highest pressure that can be generated in the system. We recommend that Edwards flexible bellows are used.
- Use a suitable inlet-filter if condensable vapours are pumped or if the pump is used for very dusty applications.
- Use a suitable valve to isolate the pump from the vacuum system if pumping condensable vapours or to maintain vacuum when the pump is switched off.
- Ensure that sealing surfaces are clean and scratch-free.

3.7.2 Side inlet-port connection

Refer to [Figure 1](#). A side inlet-port is available; use the following procedure for instructions on using this port.

1. Carefully remove the side panel (15) from the pump: use a suitable flat blade screwdriver or similar tool for this purpose. The panel is secured by two nylon rivets.
2. Unscrew and remove the blanking plug (14) with its O-ring (13).
3. Unscrew and remove the adaptor flange (4) and its O-ring and replace it with the blanking plug and O-ring that you removed in Step 2.
4. Screw the adaptor flange and its O-ring into the side inlet-port.

3.8 Connect the pump outlet



WARNING

Connect the pump outlet to a suitable treatment plant to prevent the discharge of dangerous gases and vapours to the surrounding atmosphere. Use a catchpot to prevent the drainage of contaminated condensate back into the pump.

To connect the pump to your outlet accessories or to your exhaust treatment plant, you can:

- Connect 10 mm internal diameter vacuum hose or 12 mm internal diameter plastic hose to the outlet nozzle ([Figure 1](#), item 7).
- Remove the outlet nozzle and connect to the $\frac{3}{8}$ inch BSP tapped hole.
- Remove the outlet nozzle and replace it with an NW25 flange adaptor (available as an optional accessory, refer to [Section 7.4](#)) and then connect to the NW25 flange.

Take note of the following information before connecting to the pump outlet:

- The exhaust system must be configured so that the maximum pressure at the pump outlet does not exceed 0.5 bar gauge (1.5 bar absolute, 1.5×10^5 Pa, 21.75 psi) at full pump throughput.
- In the following circumstances, Edwards recommend an oil mist filter is fitted to the pump outlet
 - if the pump is used with the gas-ballast control open
 - if the pump is operated with an inlet pressure greater than 10 mbar (7.5 Torr) for extended periods or
 - if the pump is frequently pumped down from atmospheric pressure.
- The mist filter will trap the oil exhausted from the pump: the oil can be re-used if it is not contaminated.

3.9 Leak-test the system

Leak-test the system and seal any leaks found after the pump is installed, to prevent leakage of substances out of the system and leakage of air into the system.

This page has been intentionally left blank.

4 Operation



WARNING

Do not expose any part of your body to vacuum. If you do, you may be injured.

4.1 ATEX directive implications

4.1.1 Introduction

This equipment is designed to meet the requirements of Group II Category 3 equipment in accordance with Directive 94/9/EC of the European Parliament and the Council of 23rd March 1994 on the approximation of the laws of the Member States concerning equipment and protective systems intended for use in potentially explosive atmospheres. (The ATEX Directive)

The ATEX Category 3 applies in respect of potential ignition sources internal to the equipment. An ATEX Category has not been assigned in respect of potential ignition sources on the outside of the equipment as the equipment has not been designed for use where there is an external potentially explosive atmosphere.

There is no potential source of ignition within the pump during normal operation but there may be potential sources of ignition under conditions of predictable and rare malfunction as defined in the Directive. Accordingly, although the pump is designed to pump flammable materials and mixtures, operating procedures should ensure that under all normal and reasonably predictable conditions, these materials and mixtures are not within explosive limits. Category 3 is considered appropriate for the avoidance of ignition in the case of a rare malfunction which allows flammable materials or mixtures to pass through the pump whilst within their explosive limits.

4.1.2 Flammable/pyrophoric materials



WARNING

You must obey the instructions and take note of the precautions given below, to ensure that pumped gases do not enter their flammable ranges.

When flammable or pyrophoric materials are present within the equipment you must:

- Not allow air to enter the equipment.
- Ensure that the system is leak tight.
- Use an inert gas purge (for example, a nitrogen purge) to dilute any flammable gases or vapours entering the pump inlet, and/or use an inert gas purge to reduce the concentration of flammable gases or vapours in the pump and in the exhaust pipeline to less than one quarter of the gases' published lower explosive limits (LEL).
- Use an inert gas purge into the pump gas ballast connection to prevent the condensation of flammable vapours within the pump mechanism and exhaust pipeline.

4.1.3 Gas purges



WARNING

If inert gas purges are used to dilute dangerous gases to a safe level, ensure that the pump is shut down if an inert gas supply fails.



WARNING

You must obey the instructions and take note of the precautions given below, to ensure that pumped gases do not enter their flammable ranges.

Switch on the inert gas purge to remove air from the pump and the exhaust pipeline before the process starts. Switch off the purge flow at the end of the process only after any remaining flammable gases or vapours have been purged from the pump and exhaust pipeline.

If liquids that produce flammable vapours could be present in the pump foreline, then the inert gas purge to the pump should be left on all the time this liquid is present. Flammable liquids could be present in the foreline as a result of condensation, or may be carried over from the process.

When calculating the flow rate of inert gas required for dilution, consider the maximum flow rate for the flammable gases/vapours that could occur. For example, if a mass flow controller is used to supply flammable gases to the process, assume a flow rate for flammable gases that could arise if the mass flow controller is fully open.

Continually measure the inert gas purge flow rate: if the flow rate falls below that required, you must stop the flow of flammable gases or vapours into the pump.

Note: We recommend that you obtain and read the *Vacuum Pump and Vacuum System Safety manual* (publication number P400-40-100), available from Edwards or your supplier.

4.2 Gas-ballast control

Use the gas-ballast control (Figure 1, item 5) to change the amount of air (or inert gas) introduced into the low vacuum stage of the pump. Use of the gas-ballast will prevent the condensation of vapours in the pump; the condensates would contaminate the oil.

Use the gas-ballast control closed:

- to achieve ultimate vacuum
- to pump dry gases.

Turn the gas-ballast control six turns anti-clockwise to open it fully. Use the gas-ballast control open:

- to pump high concentrations of condensable vapour
- to decontaminate the oil.

When you operate the pump with the gas-ballast control open, there will be an increased rate of oil loss from the pump.

4.3 Start-up procedure



WARNING

Ensure that your system design does not allow the exhaust pipeline to be blocked.

If the oil is contaminated, or if the pump temperature is below 12 °C (54 °F), or if the electrical supply voltage is more than 10% below the lowest voltage specified for the pump, the pump may operate at a reduced speed for a few minutes. If the pump continues to operate at reduced speed, the motor thermal overload device will open and stop the pump. When the motor has cooled, the thermal overload device will reset automatically and the pump will restart.

1. Check that the pump oil-level is between the MAX and MIN marks on the bezel of the oil-level sight-glass; if it is not, refer to [Section 5.3](#).
2. Turn the gas-ballast control to the required position (refer to [Section 4.2](#)).
3. Switch on the electrical supply to the pump.
4. Check that the oil-level in the sight-glass drops slightly (3 to 5 mm, 0.1 to 0.2 inches) after start-up. This shows that the pump has primed with oil.
5. If the pump fails to prime, operate the pump with the inlet open to atmosphere for approximately 30 seconds. Then isolate the inlet and check that the oil-level drops by 3 to 5 mm (0.1 to 0.2 inches).
6. To achieve ultimate vacuum, to pump condensable vapours or to decontaminate the pump oil, refer to the procedures in [Sections 4.4](#), [4.5](#) and [4.6](#) respectively. Otherwise, open the vacuum system isolation-valve.

4.4 To achieve ultimate vacuum

If the pump does not achieve the performance specified in [Section 2.2](#), make sure that this is not due to your system design before you contact your supplier or Edwards for advice. In particular, the vapour pressure of all materials used in your vacuum system (including pump oil, see below) must be much lower than the specified ultimate vacuum of the pump. Refer to [Table 8](#) for a list of possible causes for failure to achieve the specified performance; note however that the most common causes are:

- The pressure measurement technique or gauge head is unsuitable or the gauge head is faulty.
- Oil other than that recommended has been used and the vapour pressure of the oil is higher than the specified ultimate vacuum of the pump.

Use the following procedure to achieve ultimate vacuum:

1. Isolate the pump from your vacuum system.
2. Turn the gas-ballast control fully anti-clockwise (fully open) and operate the pump for at least 1 hour (or overnight) to thoroughly purge the oil of contaminants.
3. Close the gas-ballast control.
4. Open the vacuum system isolation-valve and pump down to ultimate vacuum.

4.5 To pump condensable vapours

Use gas-ballast (open the gas-ballast control) when there is a high proportion of condensable vapours in the process gases.

1. Close the vacuum system isolation-valve.
2. Turn the gas-ballast control anti-clockwise to the fully open position, and operate the pump for 30 minutes to warm the oil; this will help to prevent vapour condensation in the pump.
3. Open the vacuum system isolation-valve and continue to operate the pump with the gas-ballast control open.

After condensable vapours have been pumped, decontaminate the oil (if necessary); use the procedure in [Section 4.6](#).

4.6 To decontaminate the oil

The oil in the pump should be clear, if the oil is cloudy or discoloured, it is contaminated with process vapours.

1. Look at the condition of the oil in the oil sight-glass ([Figure 1](#), item 9). If the oil is cloudy or discoloured, continue with the procedure at Step 2 below.
2. Close the vacuum system isolation-valve.
3. Turn the gas-ballast control fully anti-clockwise.
4. Operate the pump until the oil is clear.

4.7 Unattended operation

The pump is designed for unattended operation under the normal operating conditions specified in [Section 2](#). However, Edwards recommend checking the pump at a regular interval of not more than 14 days; check the pump more frequently if pumping high volumes of gas or if operating the pump with the gas-ballast control open.

The motor is protected by an overload device which isolates the pump from the electrical supply when critical temperature or current levels are exceeded. The overload device resets automatically when the motor has cooled. When checking the pump, make sure that the pump is not going through a repetitive cycle of thermal overload failures and automatic resets. If necessary reduce the thermal load from the pumped gases, to prevent overheating of the pump.

4.8 Shut-down

Note: *If the gas-ballast control is open and the motor is switched off for any reason, the pump drive shaft may rotate in the reverse direction, causing a system pressure rise. To prevent this, use a gas-ballast control valve (refer to [Section 7.4.11](#)).*

Edwards recommend, as described in the procedure below, that the oil is decontaminated before the pump is shut down; this will prevent damage to the pump by the contaminants in the oil.

1. Refer to [Section 4.6](#) and decontaminate the oil, as required.
2. Close the vacuum system isolation-valve (if not already closed).
3. Close gas-ballast (that is, turn the gas-ballast control clockwise).
4. Switch off the electrical supply to the pump.

5 Maintenance

5.1 Safety information



WARNING

Obey the safety instructions given below and take note of appropriate precautions. If you do not, you can cause injury to people and damage to equipment.

- A suitably trained and supervised technician must maintain the pump. Obey your local and national safety requirements.
- Ensure that the maintenance technician is familiar with the safety procedures which relate to the pump-oil and the products processed by the pumping-system.
- Allow the pump to cool to a safe temperature before starting maintenance work.
- Isolate the pump and other components in the pumping system from the electrical supply so that they can not be operated accidentally.
- After maintenance is completed, recheck the pump rotation direction if the electrical supply has been disconnected.
- Do not reuse O-rings and seals if they are damaged.
- The pump and its fluid will be contaminated with the process chemicals that have been pumped during operation. Ensure that the pump is decontaminated before maintenance and that adequate precautions are taken to protect people from the effects of dangerous substances if contamination has occurred.
- Do not touch or inhale the thermal breakdown products of fluorinated materials which may be present if the pump has been heated to 260°C (500°F) and above. These breakdown products are very dangerous. Fluorinated materials in the pump may include oils, greases and seals. The pump may have overheated if it was misused, if it malfunctioned or if it was in a fire. Edwards Material Safety Data Sheets for fluorinated materials used in the pump are available on request: contact your supplier or Edwards.
- Leak-test the system after maintenance work is complete if you have connected or disconnected any vacuum or exhaust joints; seal any leaks found.

5.2 Maintenance plan

The plan shown in [Table 7](#) details the routine maintenance operations necessary to maintain the pump in normal use. Instructions for each operation are given in the section shown.

More frequent maintenance may be required if the pump is used to process corrosive or abrasive gases and vapours; in these circumstances, Edwards recommend that the pump seals are replaced every year. If necessary, adjust the maintenance plan according to your experience.

When maintaining the pump, use Edwards spares and maintenance kits; these contain all of the components necessary to complete maintenance operations successfully. The Item Numbers of the spares and kits are given in [Section 7](#).

Examine the condition of any external accessories, filters or traps (if fitted) when maintaining the pump. Refer to the instructions supplied with the accessories for the necessary maintenance procedures.

Table 7 - Maintenance plan

Operation	Frequency	Refer to Section
Check the oil-level	Monthly	5.3
Replace the oil	Every 3000 hours of operation	5.4
Inspect and clean the inlet-filter	Every oil change	5.5
Clean or replace the gas-ballast O-ring	Every oil change	5.6
Clean the motor fan-cover	Yearly	5.7
Clean and overhaul the pump	Every 15000 hours of operation	5.8
Fit new blades	Every 30000 hours of operation	5.9
Replace the capacitor	Every 4 years	5.10
Test the motor condition	Every 15000 hours of operation	5.10

5.3 Check the oil-level

Note: If required, the oil-level can be checked while the pump is operating, however the pump must be switched off and isolated and other components in the pumping system from the electrical supply before oil is poured into the pump.

Refer to [Figure 1](#) for the items in brackets.

1. Check that the oil-level in the sight-glass (9) is between the MAX and MIN level marks on the bezel of the sight-glass.
2. If the oil-level is near to or below the MIN level mark, remove the filler-plug (6) and pour more oil into the reservoir until the oil reaches the MAX level mark. If the oil-level goes above the MAX mark, remove the drain-plug (11) and drain the excess oil from the pump. Refit the filler-plug.
3. If the oil is contaminated, drain and refill the pump with clean oil as described in [Section 5.4](#).

5.4 Replace the oil

Refer to [Figure 1](#) for the items in brackets.

1. Operate the pump for approximately ten minutes to warm the oil, then switch off the pump. (this lowers the viscosity of the oil and enables it to be drained from the pump more easily).
2. Isolate the pump from your electrical supply and disconnect it from the vacuum system.
3. Remove the oil filler-plug (6).
4. Place a suitable block under the pump-motor to tilt the pump and place a suitable container under the drain-plug (11). Remove the drain-plug and allow the oil to drain into the container.
5. If the oil is dirty or contaminated, pour clean oil into the pump and allow it to drain out of the pump. Repeat this step until the oil reservoir is clean.
6. Refit the drain-plug, remove the block and reconnect the pump to the vacuum system.
7. Fill a suitable container with clean oil and pour the oil into the filler hole until the oil-level reaches the MAX level mark on the bezel of the sight-glass (9).
8. Allow a few minutes for the oil to drain into the pump. If necessary, add more oil. Refit the filler-plug.

5.5 Inspect and clean the inlet-filter

1. Refer to [Figure 4](#). Unscrew the inlet adaptor (1) and remove the inlet-filter (2) and O-ring (3).
2. Wash the filter in a suitable cleaning solution. Allow the filter to dry.
3. Refit the O-ring (3), inlet-filter (2) and inlet adaptor (1).

Figure 4 - Inlet-filter removal and replacement

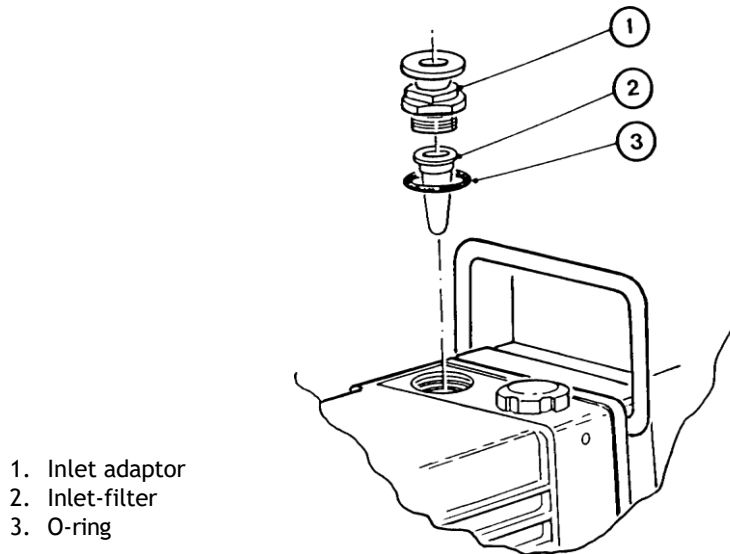

5.6 Clean or replace the gas-ballast O-ring

Note: The filter element ([Figure 5](#), item 3) is retained in its seating with adhesive; do not try to remove it.

Refer to [Figure 5](#).

1. Unscrew and remove the gas-ballast control (1).
2. Remove the O-ring (2) from the control.
3. Wash the O-ring in a suitable cleaning solution. Replace the O-ring if it is damaged.
4. Fit the O-ring carefully on its seat. Screw the gas-ballast control back into the pump, and reset to the required position.

Figure 5 - Gas-ballast O-ring removal and replacement

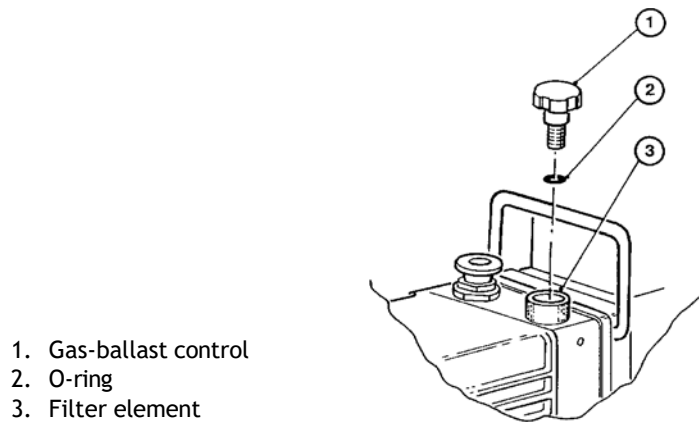

1. Gas-ballast control
2. O-ring
3. Filter element

5.7 Clean the motor fan-cover and enclosure

If the motor fan-cover and enclosure are not kept clean, the air-flow over the motor can be restricted and the pump may overheat.

1. Switch off the pump and disconnect it from the electrical supply.
2. Use a dry cloth and a soft brush to remove dirt and deposits from the fan-cover and enclosure.

5.8 Clean and overhaul the pump

Clean and overhaul the pump as described in the instruction supplied with the clean and overhaul kit (refer to Section 7.3).

5.9 Fit new blades

Fit new blades to the pump as described in the instructions supplied with the blade kit (refer to Section 7.3).

5.10 Replace the capacitor and test the motor

Replace the capacitor as described in the instructions supplied with the capacitor kit.

Test the earth (ground) continuity and the insulation resistance of the pump motor, in accordance with local regulations for periodic testing of electrical equipment. Edwards recommends that:

- The earth (ground) continuity is less than 0.1Ω .
- Insulation resistance is greater than $10 M\Omega$.

If the motor fails these tests, the motor must be replaced.

5.11 Fault finding

A list of fault conditions and their possible causes is provided in Table 8 to assist in basic fault-finding. If unable to rectify a fault when using this guide, call your supplier or your nearest Edwards Service Centre for advice.

Table 8 - Fault finding

Fault condition	Possible cause
The pump has failed to start	The electrical supply fuse has failed. The motor is incorrectly wired. The operating voltage does not match that of the motor. The exhaust filter or exhaust line is blocked. The oil temperature is below 12°C (53.6°F). The oil is too viscous. The oil is contaminated. The pump is seized after long storage, or has been left to stand after pumping contaminants. The motor is faulty.
The pump failed to achieve specified performance (Failure to reach ultimate vacuum)	Your measuring technique or gauge is unsuitable. There is a leak in the external vacuum system. The gas-ballast control is open. The oil level is too low. You have filled the pump with the wrong type of oil. The oil is contaminated. The pump has not primed. The vacuum fittings are dirty. The inlet-filter is blocked. The pump has not warmed up.
The pump is noisy	The motor fan-cover is damaged. The motor bearings are worn. The oil is contaminated with solid particles. One of the pump blades is sticking.
The pump surface temperature is above 100°C (212°F)	The ambient temperature is too high. The cooling-air supply is insufficient or is too hot. The cooling-air supply is blocked. The electrical supply voltage is too high. The exhaust filter or exhaust line is blocked. The oil level is too low. The pump is filled with the wrong type of oil. The oil is contaminated. The process gas is too hot, or the throughput is too high.
The vacuum is not maintained after the pump is switched off	The gas-ballast control is open. O-ring (s) are damaged or missing. The shaft seals have deteriorated.
The pumping speed is poor	The connecting pipelines are too small in diameter. The connecting pipelines are too long. The inlet-filter is blocked.

Table 8 - Fault finding (continued)

Fault condition	Possible cause
There is an external oil leak	The oil pump shaft seal is worn or damaged. The oil box O-ring has deteriorated. There is an oil leak from gas-ballast control. There is an oil-leak from the drain-plug.

6 Storage and disposal

6.1 Storage

CAUTION

Observe the storage temperature limits stated in [Section 2.1](#). Storage below -30°C (-22°F) will permanently damage the pump seals.

Note: *If the new pump is to be stored in conditions of high humidity, remove the pump from the packaging and dispose of the packaging in accordance with the instruction in [Section 6.2](#).*

Use the following procedure to store the pump:

1. Shut-down the pump as described in [Section 4.8](#).
2. Disconnect the pump from the electrical supply.
3. Purge the vacuum system and the pump with dry nitrogen and disconnect the pump from the vacuum system.
4. Replace the oil as described in [Section 5.4](#).
5. Place and secure protective covers over the inlet and outlet-ports.
6. Store the pump in cool, dry conditions until required for use.

When required, prepare and install the pump as described in [Section 3](#). If the pump has been stored for more than a year, clean and overhaul the pump before installing it, as described in the instructions supplied with the clean and overhaul kit.

6.2 Disposal

Dispose of the pump, the oil and any components removed from the pump safely in accordance with all local and national safety and environmental requirements.

Take particular care with the following:

- Components which have come into contact with the pump fluid.
- Components which have been contaminated with dangerous process substances.

Do not incinerate fluoroelastomer seals and O-rings.

This page has been intentionally left blank.

7 Service, spares and accessories

7.1 Introduction

Edwards products, spares and accessories are available from Edwards companies in Belgium, Brazil, China, France, Germany, Israel, Italy, Japan, Korea, Singapore, United Kingdom, U.S.A and a world-wide network of distributors. The majority of these centres employ Service Engineers who have undergone comprehensive Edwards training courses.

Order spare parts and accessories from your nearest Edwards company or distributor. When you order, state for each part required:

- Model and Item Number of your equipment
- Serial number
- Item Number and description of part.

7.2 Service

Edwards products are supported by a world-wide network of Edwards Service Centres. Each Service Centre offers a wide range of options including: equipment decontamination; service exchange; repair; rebuild and testing to factory specifications. Equipment which has been serviced, repaired or rebuilt is returned with a full warranty.

Your local Service Centre can also provide Edwards engineers to support on-site maintenance, service or repair of your equipment.

For more information about service options, contact your nearest Service Centre or other Edwards company.

7.3 Spares

The maintenance kits listed in [Table 9](#) contain all of the parts you will need to maintain your pump. The maintenance kits also include instructions for the use of the kits.

Use the Clean and Overhaul Kit for routine maintenance operations. Use the Blade Kit together with the Clean and Overhaul Kit when the blade assembly in the rotary pump must be renewed.

Table 9 - Spares Item Numbers

Maintenance kit	Item Number
E2M0.7/E2M1.5 Clean and Overhaul Kit	A371-01-131
E2M0.7/E2M1.5 Blade Kit	A371-01-132
Ultragrade 15 oil, 1 litre	H110-26-015
Capacitor kit for part numbers A371-31-902 / A371-22-902 / A371-03-902 (110-120 V 30 μ F)	A505-84-808
Capacitor kit for part numbers A371-31-919 / A371-22-919 / A371-03-919 (220-240 V 8 μ F)	A505-84-809

7.4 Accessories

7.4.1 Introduction

A comprehensive range of accessories is available for the pumps, as shown in Figure 6. Table 10 lists the Item Numbers of these accessories, and the accessories are briefly described in Sections 7.4.2 to 7.4.12.

Table 10 - Accessories Item Numbers

Accessory	Refer to Section	Item Number
IT020K Inlet catchpot *	7.4.2	A441-10-000
ITF20K Inlet dust filter *	7.4.3	A442-15-000
ITD20K Inlet desiccant trap *	7.4.4	A445-10-000
ITC20K Inlet chemical trap	7.4.5	A444-10-000
FL20K Foreline trap *	7.4.6	A133-05-000
EMF3 Outlet mist filter	7.4.7	A462-20-000
Oil drain extension	7.4.8	A505-03-000
Vibration isolators (pack of four)	7.4.9	A248-01-407
NW25 Pump inlet/outlet adaptor	7.4.10	A371-01-028
EBV20 gas-ballast control valve	7.4.11	
220/240 V, single-phase, 50/60 Hz		A500-06-930
100/120 V, single-phase, 50/60 Hz		A500-06-984
PV10EK pipeline valve *	7.4.12	
200/240 V, single-phase, 50/60 Hz		C411-01-000
110/127 V, single-phase, 50/60 Hz		C411-03-000

* These accessories require an NW25 adaptor: refer to Section 7.4.10.

7.4.2 Inlet catchpot

The inlet catchpot traps any liquid droplets and prevents their entry into the pump.

7.4.3 Inlet dust filter

The inlet dust filter protects the pump against abrasive dust.

7.4.4 Inlet desiccant trap

Use a desiccant trap when you pump limited quantities of water vapour at high pumping speeds to a low vapour pressure.

7.4.5 Inlet chemical trap

The inlet chemical trap protects the pump against chemically active gases.

7.4.6 Foreline trap

Use a Foreline trap on a clean pumping system to prevent back-migration of rotary pump oil vapour into the vacuum system.

Figure 6 - Accessories

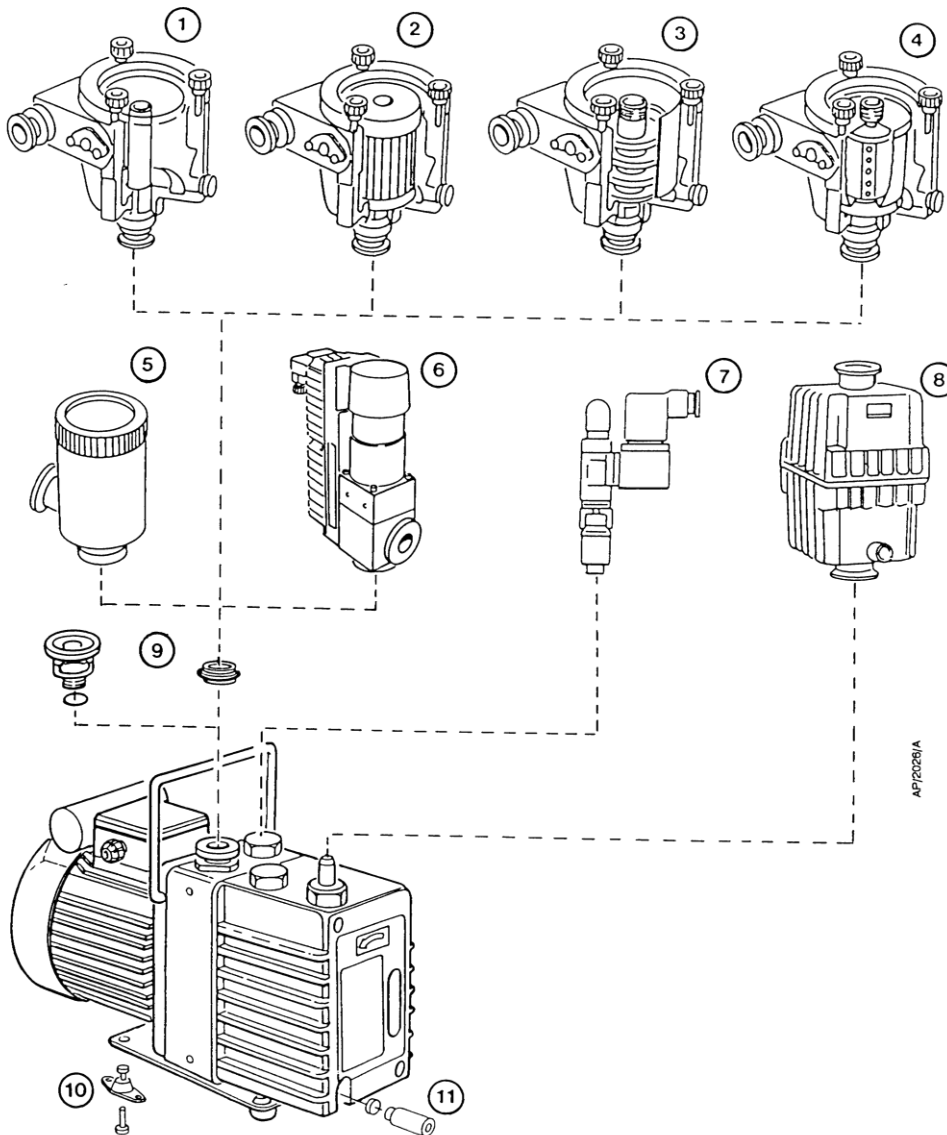

- | | |
|---|--|
| <ul style="list-style-type: none"> 1. Inlet catchpot 2. Inlet dust filter 3. Inlet desiccant trap 4. Inlet chemical trap 5. Foreline trap 6. Solenoid operated pipeline valve | <ul style="list-style-type: none"> 7. Solenoid operated gas-ballast valve 8. Outlet mist filter 9. Flange adaptor kit 10. Vibration isolators 11. Oil drain extension |
|---|--|

7.4.7 Outlet mist filter

The outlet mist filter separates and traps oil droplets to prevent oil mist discharge from the pump outlet.

7.4.8 Oil drain extension

Fit the oil drain extension between the oil drain port on the pump and the oil drain-plug to make the drainage of oil from the pump easier. The pack includes an oil drain extension tube for use when oil is gravity drained.

7.4.9 Vibration isolators

The vibration isolators reduce transmission vibration and noise when the pump is floor or frame mounted, and helps to reduce strain when the mounting area is uneven.

7.4.10 Pump inlet or outlet NW25 adaptor

This is a $\frac{3}{8}$ inch BSP to NW25 adaptor, supplied with connection hardware. Use this adaptor when the NW10 adaptor fitted to the pump-inlet or the outlet-nozzle fitted to the pump outlet are removed, to adapt the $\frac{3}{8}$ inch BSP thread to NW25.

7.4.11 Solenoid operated gas-ballast control valve

The valve provides remote or automatic on/off control of gas-ballast. The valve can be connected to shut-off ballast to prevent the return of air to the vacuum system when the pump is switched off.

7.4.12 Solenoid operated pipeline valve

Fit the pipeline valve between your vacuum system and the pump inlet to provide additional system protection when the pump is switched off.

This page has been intentionally left blank.

This page has been intentionally left blank.

Return the equipment or components for service

Before you send your equipment to us for service or for any other reason, you must send us a completed Declaration of Contamination of Vacuum Equipment and Components - Form HS2. The HS2 form tells us if any substances found in the equipment are hazardous, which is important for the safety of our employees and all other people involved in the service of your equipment. The hazard information also lets us select the correct procedures to service your equipment.

We provide instructions for completing the form in the Declaration of Contamination of Vacuum equipment and Components - Procedure HS1.

If you are returning a vacuum pump, note the following:

- If a pump is configured to suit the application, make a record of the configuration before returning the pump. All replacement pumps will be supplied with default factory settings.
- Do not return a pump with accessories fitted. Remove all accessories and retain them for future use.
- The instruction in the returns procedure to drain all fluids does not apply to the lubricant in pump oil reservoirs.

Download the latest documents from www.edwardsvacuum.com/HSForms/, follow the procedure in HS1, fill in the electronic HS2 form, print it, sign it, and return the signed copy to Edwards.

Note: *If we do not receive a completed HS2 form, we will not accept the return of the equipment.*

